

CRM 700 MELTING CRUCIBLE FURNACE

PRODUCT DATA SHEET

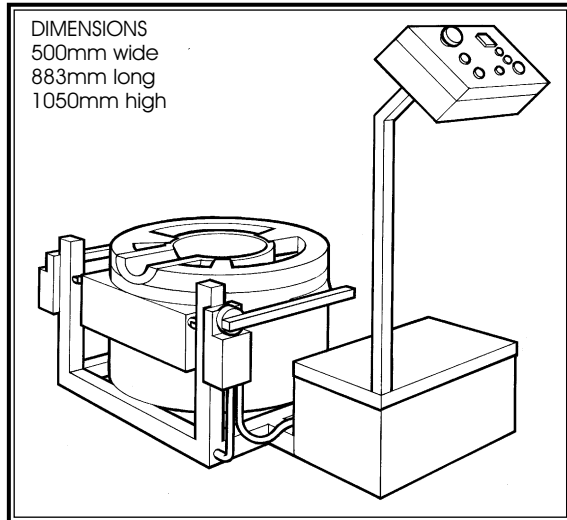

All valves and pipe work, including the whisper quiet blower fan, are included within the self-contained cabinet.

Safe operation is by panel mounted controls. Ignition is automatic and there is automatic flame control with no user interaction required.

On ignition, the crucible furnace is automatically put on low heat for about 5 minutes to preheat the chamber and crucible pot before ramping up to full heat input. This helps to reduce the risk of thermal shock.

The CRM 700 has a motorised safety tilt system that is push-button operated. When the tilt button is pressed the unit will slowly rise from the rest position towards the pouring position. At the pouring position the unit will slowly pour the molten metal into the mould. When the tilt button is released, the unit begins to return to the rest position. The unit can be held in one position by continuously pressing and releasing the tilt button.

This furnace has the ability to think for itself. It can re-establish firing conditions, maintain correct gas/air ratios and shut off safely if the mains electrical power or gas is cut off. Efficient insulation and refractor materials give fast heating together with fuel gas economy.

Designed to work with natural gas, propane, or butane.

According to the Health & Safety at Work Act 1974, BS 4163 and COSHH Regulations it is mandatory that all fumes must be removed at source.

- ◆ Please state type of gas when ordering ◆

FLAMEFAST (UK) LTD

UNIT 2 · Labtec Street · Swinton · Manchester M27 8SE
Tel 0161 793 9998 · Fax 0161 793 0098
www.flamefast.co.uk · e-mail: sales@flamefast.co.uk

SPECIFICALLY DESIGNED FOR USE IN INDUSTRY AND EDUCATION, THE CRM 700 CRUCIBLE FURNACE IS CAPABLE OF MELTING A RANGE OF METALS INCLUDING ALUMINIUM, BRASS, BRONZE, GOLD AND SILVER .

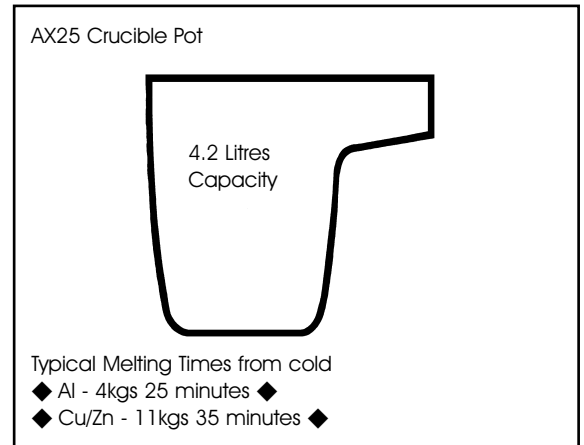

PERFORMANCE

GAS TYPE	RATE	BTU/Hr	Kw	Pressure
Natural	2.73m ³ /h	100,000	29.3	20 mbar
Propane	2.1kg/h	100,000	29.3	35 mbar
Butane	2.1kg/h	100,000	29.3	28 mbar
Maximum Temperature				1200 C
Electrics	100Watts · 220 - 240 Volt single phase			
Weight				75 Kg

STANDARD EQUIPMENT

- ◆ Whisper quiet blower fan.
- ◆ Super efficient insulation.
- ◆ Push button, no volt release starter.
Requires manual restart after power failure.
- ◆ Electronic flame failure protection with automatic ignition.
- ◆ A25X crucible pot.
- ◆ Operation / Instruction manual.

OPTIONAL EXTRAS

- ◆ Replacement AX25 crucible pot.
- ◆ Face shield (Polycarbonate) (2.2mm).
- ◆ Heat resistant gloves.
- ◆ Chrome leather leggings.
- ◆ Chrome leather apron.
- ◆ Hardware support casting kit.
- ◆ Moulding bench.
- ◆ Fume extraction to meet the requirements of COSHH Regulations.