

CM 350 PB

SAFETY TILT CRUCIBLE FURNACE

PRODUCT DATA SHEET

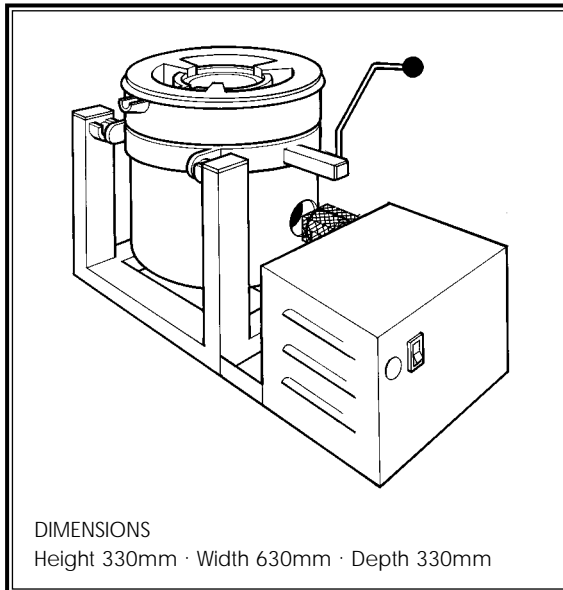

DIMENSIONS
Height 330mm · Width 630mm · Depth 330mm

STANDARD EQUIPMENT

- ◆ Fully automatic burner control and ignition system
- ◆ Super efficient insulation
- ◆ A10 Capacity crucible pot
- ◆ Crucible lid
- ◆ Tilt handle
- ◆ Pouring gauge
- ◆ Degassing plunger
- ◆ Skimming ladle/dross lifter
- ◆ Safety burner cut-out prevents burner from operating when the drum is tilted
- ◆ Operation/Instruction manual

OPTIONAL EXTRAS

- ◆ Replacement A10 crucible pot and lid
- ◆ Raised sand tray, 1200 x 800 x 300mm, removes the need for a casting pit
- ◆ Face shield
- ◆ Heat resistant gloves
- ◆ Chrome leather leggings
- ◆ Chrome leather apron
- ◆ Combined lifting and pouring tools for multiple pours
- ◆ Hardware support casting kit
- ◆ Moulding bench
- ◆ Fume extraction equipment to meet the requirements of COSHH Regulations

According to the Health & Safety at Work Act 1974, BS 4163 and COSHH Regulations it is mandatory that all fumes must be removed at source.

- ◆ Please state type of gas when ordering ◆

FLAMEFAST (UK) LTD

UNIT 2 · Labtec Street · Swinton · Manchester M27 8SE
Tel 0161 793 9998 · Fax 0161 793 0098
www.flamefast.co.uk · e-mail: sales@flamefast.co.uk

THE CM350 PB IS FITTED WITH A HIGH PERFORMANCE BURNER AND CONTROL SYSTEM INCORPORATING A FULLY AUTOMATIC START SEQUENCE WHICH IS INITIATED BY THE TOUCH OF A SWITCH. THE FURNACE OFFERS FAST MELT TIMES OVER A WIDE RANGE OF METALS, FROM ALUMINIUM TO BRONZE, BRASS, COPPER, GOLD AND SILVER.

A10 Capacity Crucible Pot

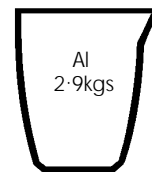

Al
2.9kgs

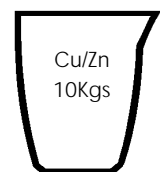

Cu/Zn
10Kgs

Typical Melting Times from cold

- ◆ Al - 2.9kgs 25 minutes ◆ Cu - 10kgs 40 minutes ◆

PERFORMANCE

GAS TYPE	RATE	BTU/Hr	Kw	Pressure
Natural	1.36m ³ /h	50000	14.6	20 mbar
Propane	1.0kg/h	50000	14.6	35 mbar
Butane	1.06kg/h	50000	14.6	28 mbar
Maximum Temperature				1100C
Electrics			50 watts 220 - 240 volts	
Weight				28 Kg

If required the drum assembly can be detached and carried to the mould using the Combined Lifting and Pouring Tools which are supplied as optional extras.

CM 353 PB

MADE SPECIFICALLY WITH THE JEWELLER IN MIND

The CM 353 PB is an alternative drum assembly available with a smaller lift out A3 crucible with a hinged lid. This feature makes it ideal for jewellers and others involved in melting small quantities of precious metals.

In tests 500 gms of brass have been melted in four minutes and gold in six.

The crucible drum has been designed so that it can be interchangeable with that of the standard drum housing the A10 crucible pot.



MAY 00

