

# FLAMEFAST MOULDING BENCH

PRODUCT DATA SHEET

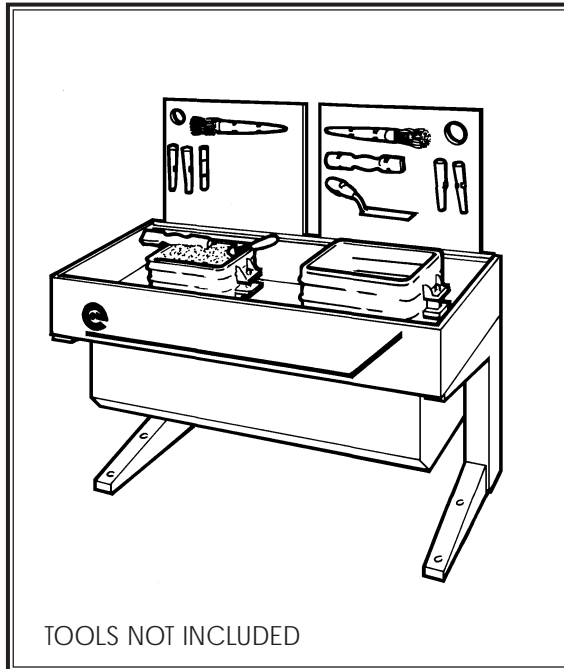

*THIS ROBUSTLY DESIGNED, ATTRACTIVE SAND MOULDING BENCH IS SPECIFICALLY DESIGNED FOR USE IN SCHOOL AND COLLEGE WORKSHOPS.*

The Flamefast Moulding Bench is rigidly constructed to be totally stable with the 200Kg sand bin full to capacity.

Aesthetically designed to match the Flamefast range of gas equipment, the Moulding Bench restricts the sand within a specific area when filling moulding flasks and so helps to keep the floor sand free and reduces the chance of accidents.

The sand bin is made of galvanised steel with a tough stove enamel finish. Guideways are provided to allow the moulding boards to slide easily from left to right.

The two part lid has a dual purpose. It covers the moulding bench when not in use and can be opened independently to give access to all or part of the sand. It also stores all the tools needed for the moulding process.

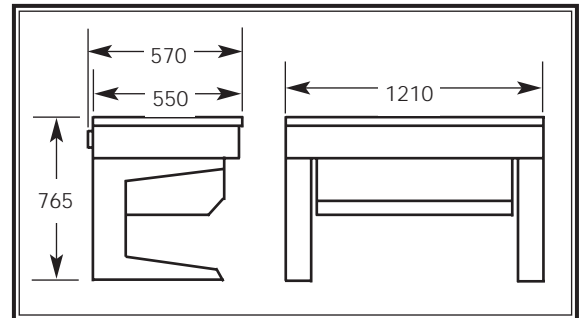

Other Product Data Sheets in the Flamefast range that may be of interest are:-

- ◆ CM 600 Rapid Melting Crucible furnaces
- ◆ CM 350PB Rapid Melting Crucible Furnace
- ◆ CM 350 Safety Tilt Crucible Furnace
- ◆ Varivac Fume Extraction
- ◆ Casting Kit

*According to the Health & Safety at Work Act 1974, BS 4163 and COSHH Regulations it is mandatory that all fumes must be removed at source.*

## FLAMEFAST (UK) LTD

UNIT 2 · Labtec Street · Swinton · Manchester M27 8SE  
Tel 0161 793 9998 · Fax 0161 793 0098  
www.flamefast.co.uk · e-mail: sales@flamefast.co.uk

